



P-Channel Enhancement Mode MOSFET

Feature

- z -60V/-20A
 $R_{DS(ON)} = 37\text{ m } (\text{typ.}) @ V_{GS} = -10\text{V}$
 $R_{DS(ON)} = 50\text{ m } (\text{typ.}) @ V_{GS} = -4.5\text{V}$
- z 100% avalanche tested
- z Reliable and Rugged
- z Halogen Free and Green Devices Available
 (RoHS Compliant)

Pin Description

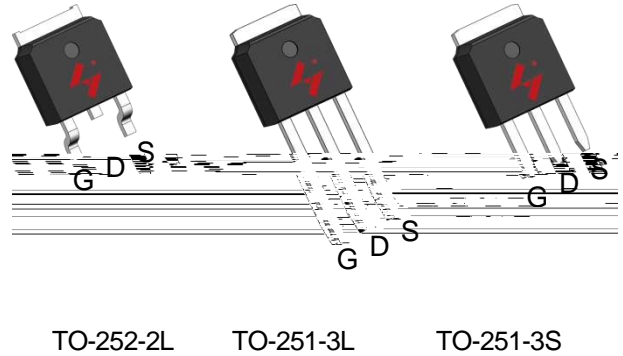

Applications

- z Switching application
- z Motor Drive

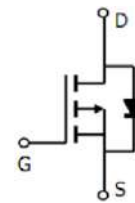

P-Channel MOSFET

Ordering and Marking Information

| | | | |
|-----------------------------------|-----------------------------------|-----------------------------------|---|
| D HYG450P06 XYMXXXXX | U HYG450P06 XYMXXXXX | V HYG450P06 XYMXXXXX | Package Code D: TO-252-2L U: TO-251-3L V: TO-251-3S Date Code XYMXXXXX |
|-----------------------------------|-----------------------------------|-----------------------------------|---|

Note: HUAYI lead-free products contain molding compounds/die attach materials and 100% matte tin plate Termination finish; which are fully compliant with RoHS. HUAYI lead-free products meet or exceed the lead-free requirements of IPC/JEDEC J-STD-020 for MSL classification at lead-free peak reflow temperature. HUAYI defines 'Green' to mean lead-free (RoHS compliant) and halogen free (Br or Cl does not exceed 900ppm by weight in homogeneous material and total of Br and Cl does not exceed 1500ppm by weight).

HUAYI reserves the right to make changes to improve reliability or manufacturability without notice, and Advise customers to obtain the latest version of relevant information to verify before placing orders.



Absolute Maximum Ratings

| Symbol | Parameter | | Rating | Unit |
|---|--|----------|------------|------|
| Common Ratings (Tc=25°C Unless Otherwise Noted) | | | | |
| V _{DSS} | Drain-Source Voltage | | -60 | V |
| V _{GSS} | Gate-Source Voltage | | ±20 | V |
| T _J | Junction Temperature Range | | -55 to 175 | °C |
| T _{STG} | Storage Temperature Range | | -55 to 175 | °C |
| I _S | Drain Current-Continuous | Tc=25°C | -20 | A |
| Mounted on Large Heat Sink | | | | |
| I _{DM} | Pulsed Drain Current * | Tc=25°C | -80 | A |
| I _D | Continuous Drain Current | Tc=25°C | -20 | A |
| | | Tc=100°C | -14 | A |
| P _D | Maximum Power Dissipation | Tc=25°C | 37.5 | W |
| | | Tc=100°C | 18.7 | W |
| R _{θJC} | Thermal Resistance, Junction-to-Case | | 4 | °C/W |
| R _{θJA} | Thermal Resistance, Junction-to-Ambient ** | | 110 | °C/W |
| E _{AS} | Single Pulsed-Avalanche Energy *** | L=0.3mH | 58*** | mJ |

Note: * Repetitive rating; pulse width limited by max junction temperature.

** Surface mounted on FR-4 board.

*** Limited by T_{Jmax}, starting T_J=25°C, L = 0.3mH, R_G= 25Ω



Electrical Characteristics (Cont.) (Tc =25°C Unless Otherwise Noted)

| Symbol | Parameter | Test Conditions | HYG450P06LA1 | | | Unit |
|--------|-----------|-----------------|--------------|-----|-----|------|
| | | | Min | Typ | Max | |

Dynamic Characteristics



Typical Operating Characteristics

Figure 1: Power Dissipation

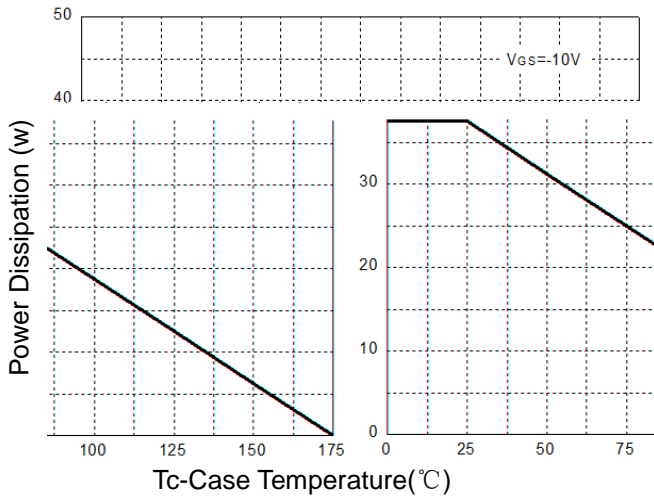

Figure 2: Drain Current

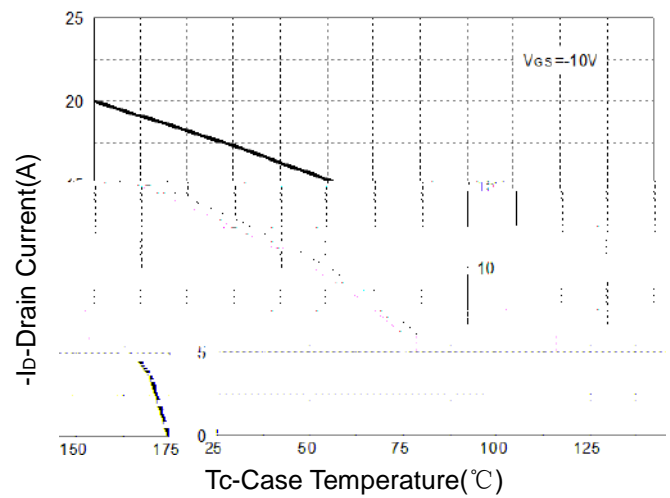

Figure 3: Safe Operation Area

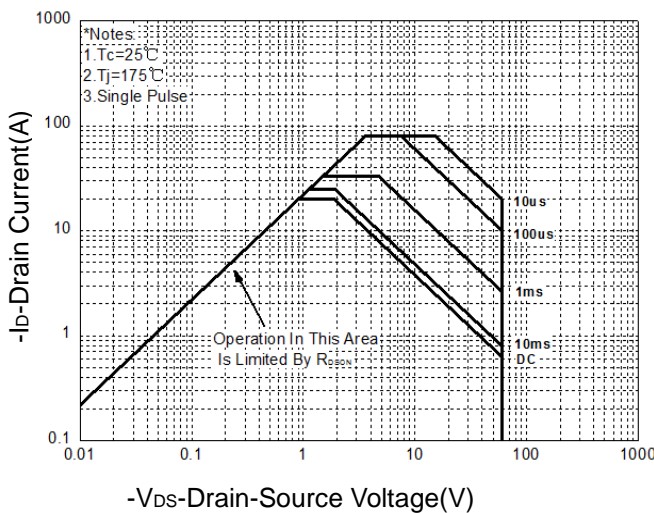

Figure 4: Thermal Transient Impedance

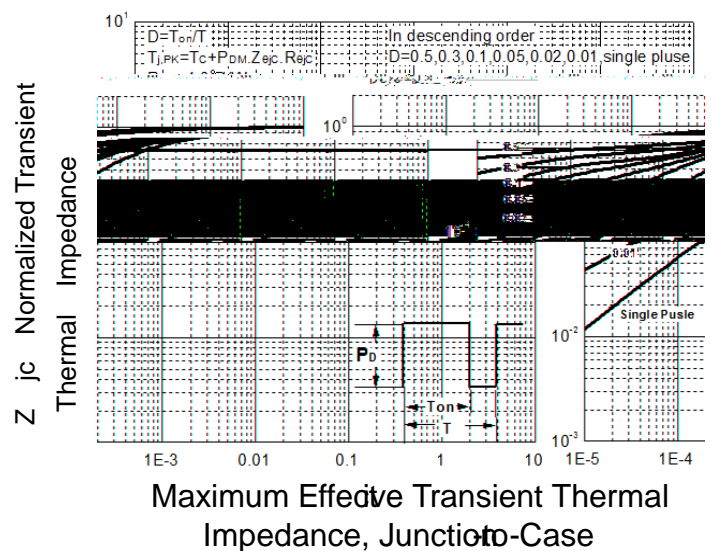

Figure 5: Output Characteristics

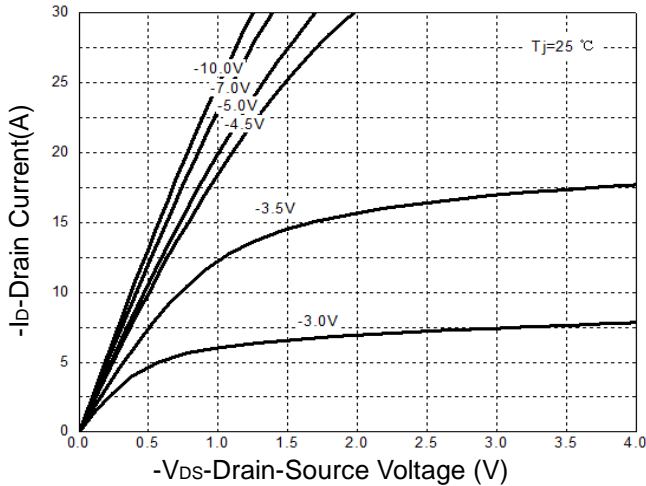
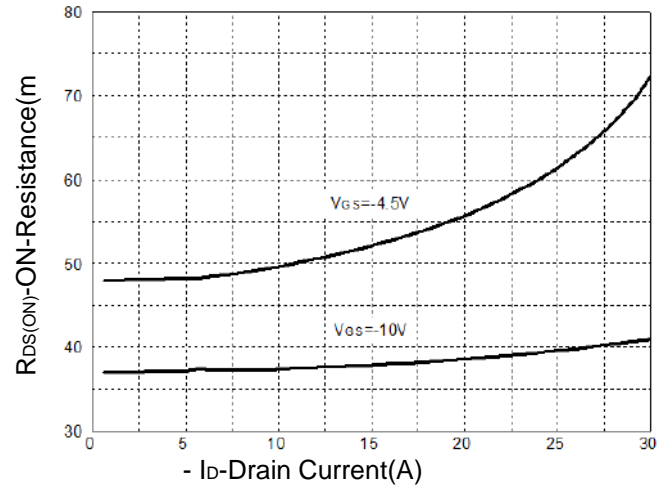

Figure 6: Drain -Source On Resistance





Typical Operating Characteristics (Cont.)

Figure 7: On-Resistance vs. Temperature

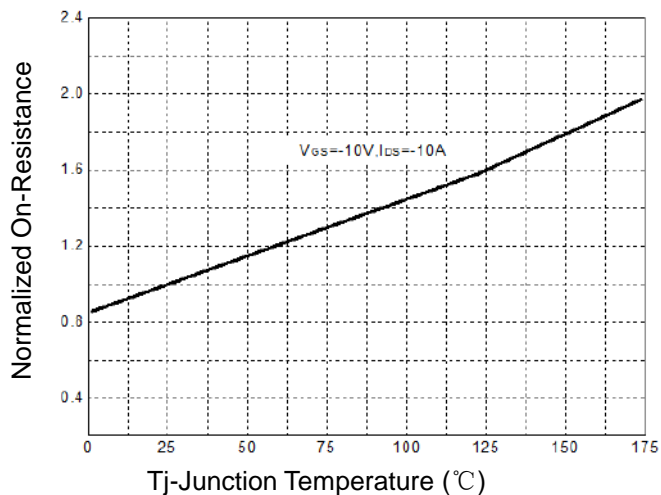

Figure 8: Source-Drain Diode Forward

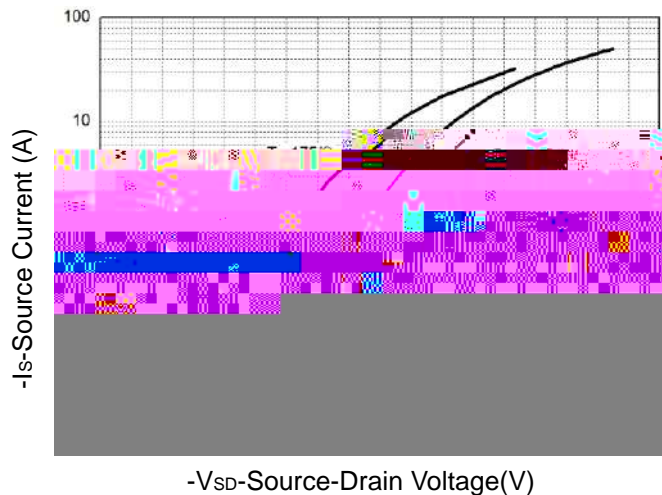

Figure 9: Capacitance Characteristics

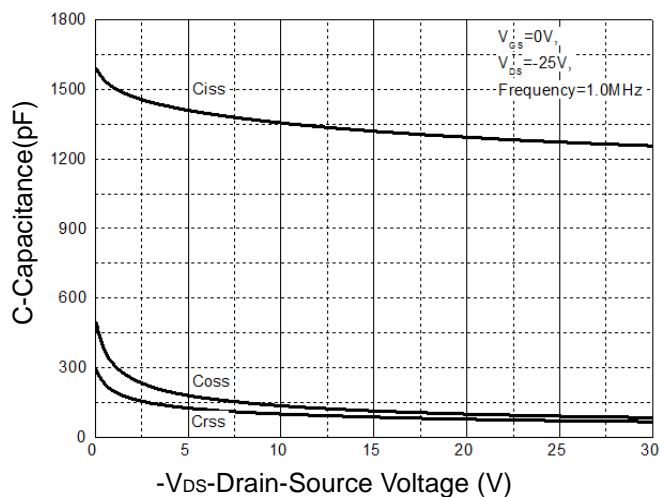
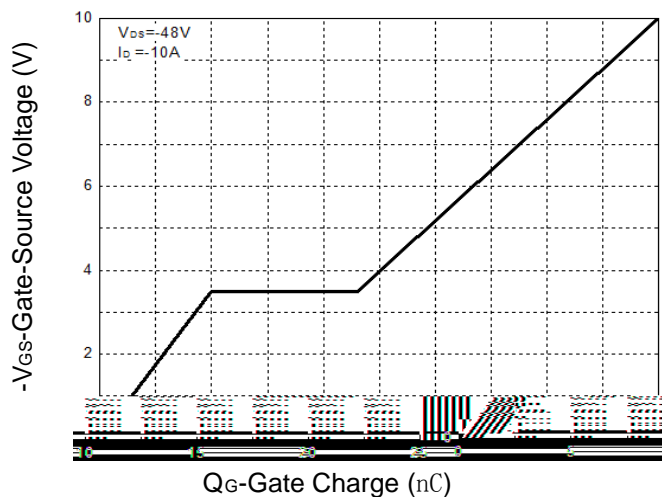
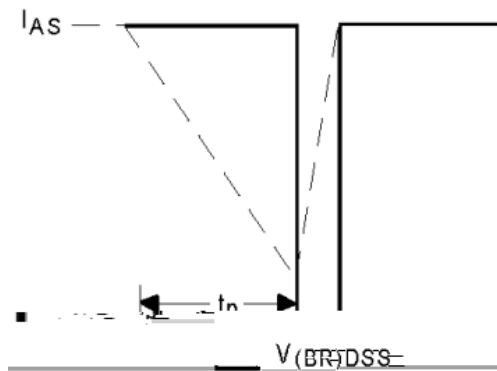
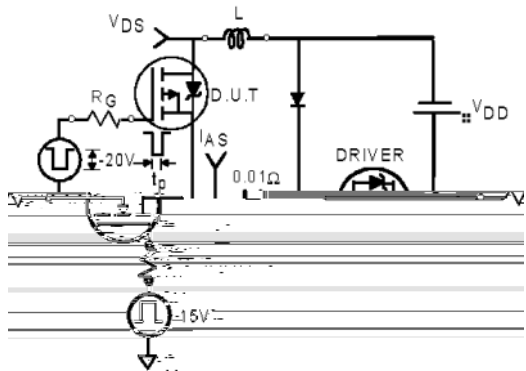

Figure 10: Gate Charge Characteristics





Avalanche Test Circuit



Switching Time Test Circuit

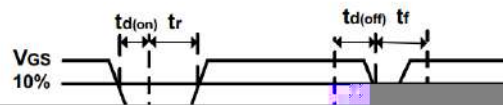
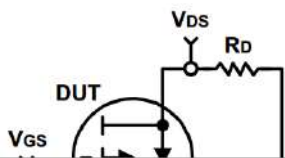

Gate Charge Test Circuit

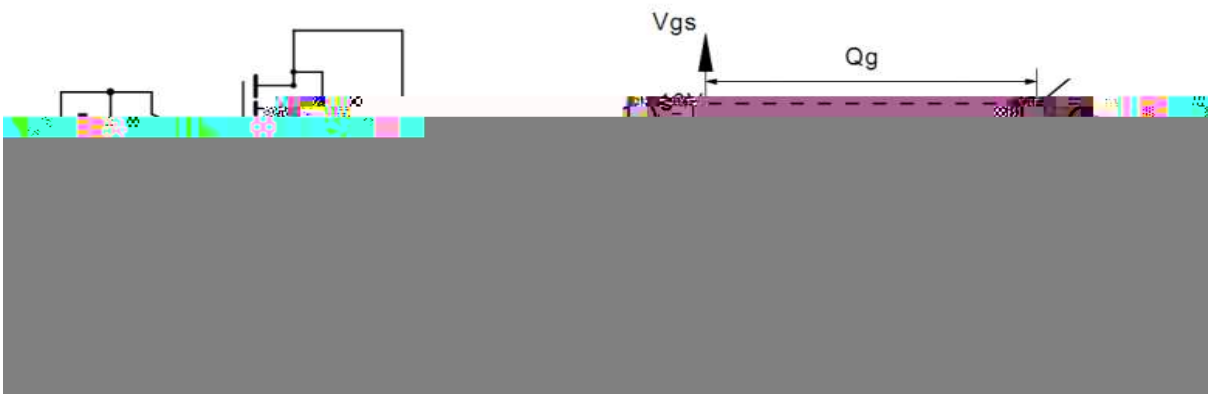

HYG450P06LA1D/U/V

Device Per Unit

| Package Type | Unit | Quantity |
|--------------|------|----------|
| TO-252-2L | Tube | 75 |
| TO-252-2L | Reel | 2500 |
| TO-251-3L | Tube | 75 |
| TO-251-3S | Tube | 75 |

Package Information

TO-252-2L

COMMON DIMENSIONS

| SYMBOL | mm | | |
|--------|----------|-------|-------|
| | MIN | NOM | MAX |
| A | 2.20 | 2.30 | 2.40 |
| A1 | 0.00 | - | 0.20 |
| A2 | 0.97 | 1.07 | 1.17 |
| b | 0.68 | 0.78 | 0.90 |
| b3 | 5.20 | 5.33 | 5.50 |
| c | 0.43 | 0.53 | 0.63 |
| D | 5.98 | 6.10 | 6.22 |
| D1 | 5.30REF | | |
| E | 6.40 | 6.60 | 6.80 |
| E1 | 4.63 | - | - |
| e | 2.286BSC | | |
| H | 9.40 | 10.10 | 10.50 |
| L | 1.38 | 1.50 | 1.75 |
| L1 | 2.90REF | | |
| L2 | 0.51BSC | | |
| L3 | 0.88 | - | 1.28 |
| L4 | - | - | 1.00 |
| L5 | 1.65 | 1.80 | 1.95 |
| | 0° | - | 8° |

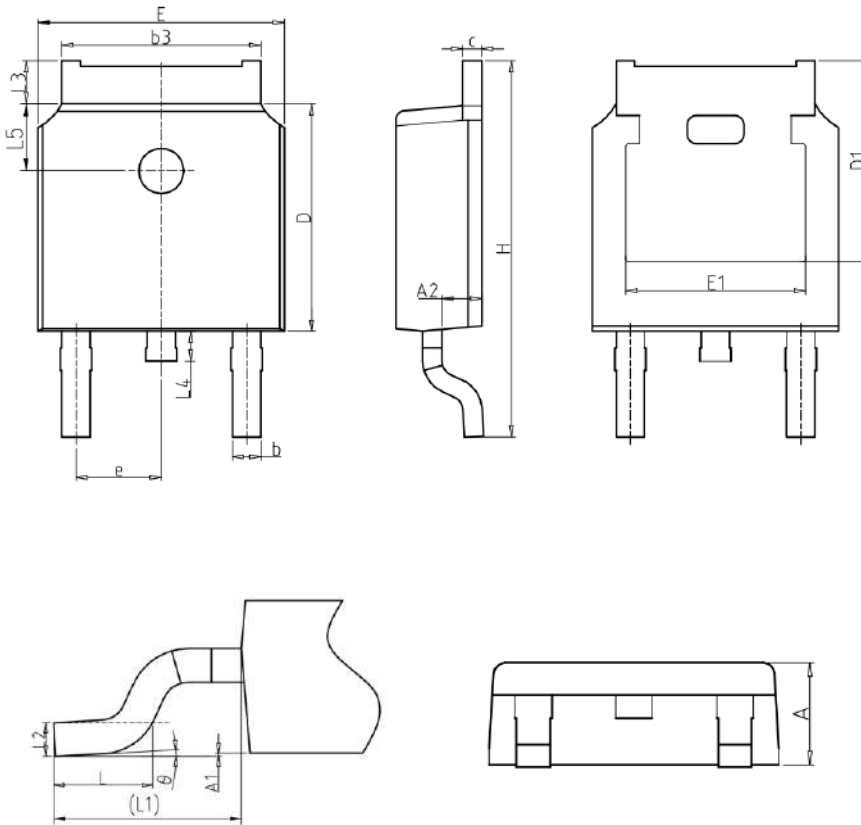



TO-251-3L

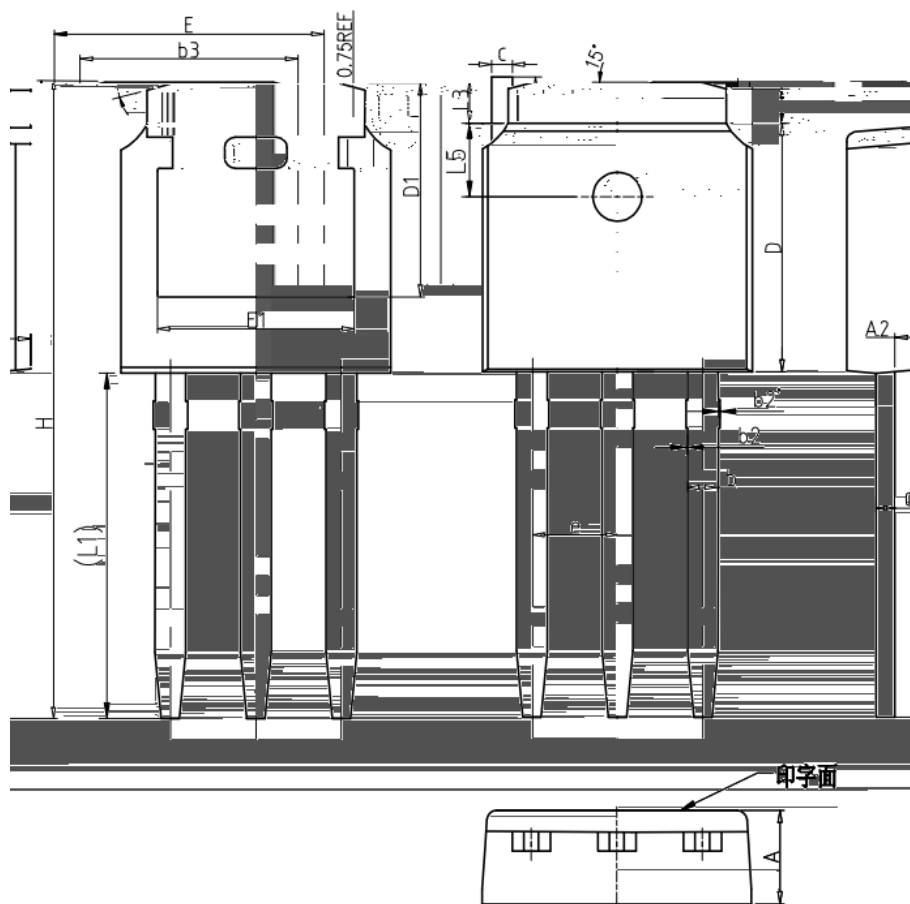

COMMON DIMENSIONS

| SYMBOL | mm | | |
|--------|----------|-------|-------|
| | MIN | NOM | MAX |
| A | 2.20 | 2.30 | 2.40 |
| A2 | 0.97 | 1.07 | 1.17 |
| b | 0.68 | 0.78 | 0.90 |
| b2 | 0.00 | 0.04 | 0.10 |
| b2' | 0.00 | 0.04 | 0.10 |
| b3 | 5.20 | 5.33 | 5.50 |
| c | 0.43 | 0.53 | 0.63 |
| D | 5.98 | 6.10 | 6.22 |
| D1 | 5.30REF | | |
| E | 6.40 | 6.60 | 6.80 |
| E1 | 4.63 | - | - |
| e | 2.286BSC | | |
| H | 16.22 | 16.52 | 16.82 |
| L1 | 9.15 | 9.40 | 9.65 |
| L3 | 0.88 | 1.02 | 1.28 |
| L5 | 1.65 | 1.80 | 1.95 |

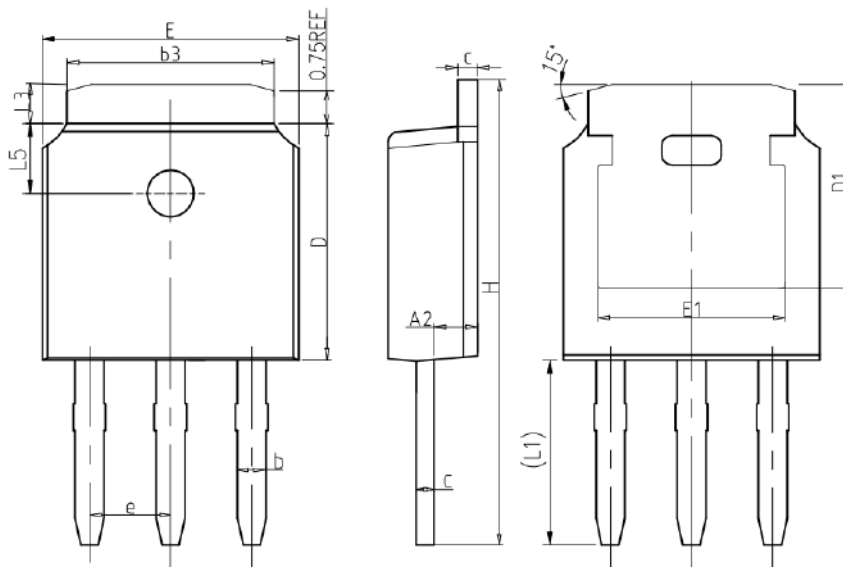

COMMON DIMENSIONS

| SYMBOL | mm | | |
|--------|----------|-------|-------|
| | MIN | NOM | MAX |
| A | 2.20 | 2.30 | 2.40 |
| A2 | 0.97 | 1.07 | 1.17 |
| b | 0.68 | 0.78 | 0.90 |
| b3 | 5.20 | 5.33 | 5.50 |
| c | 0.43 | 0.53 | 0.63 |
| D | 5.98 | 6.10 | 6.22 |
| D1 | 5.30REF | | |
| E | 6.40 | 6.60 | 6.80 |
| E1 | 4.63 | - | - |
| e | 2.286BSC | | |
| H | 10.00 | 11.22 | 11.44 |
| L1 | 3.90 | 4.10 | 4.30 |
| L3 | 0.88 | 1.02 | 1.28 |
| L5 | 1.65 | 1.80 | 1.95 |



Classification Profile

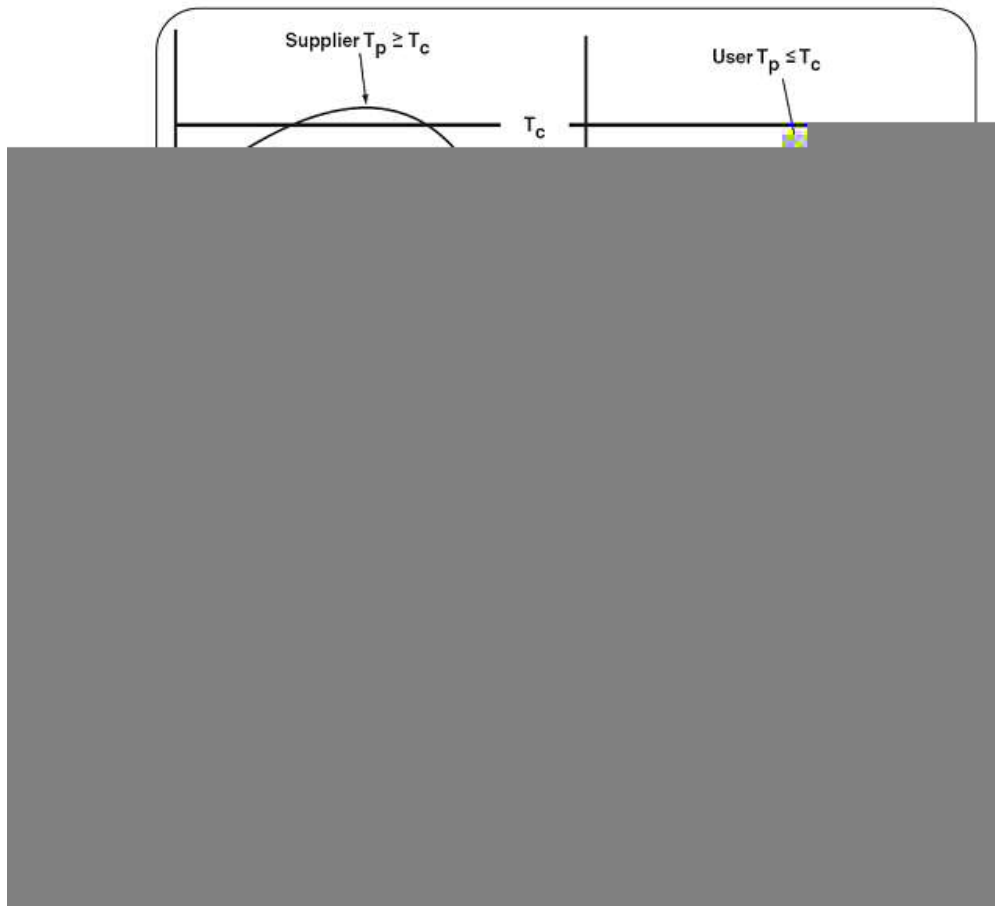

Classification Reflow Profiles

| Profile Feature | Sn-Pb Eutectic Assembly | Pb-Free Assembly |
|--|------------------------------------|------------------------------------|
| Preheat & Soak | | |
| Temperature min (T_{smin}) | 100 °C | 150 °C |
| Temperature max (T_{smax}) | 150 °C | 200 °C |
| Time (T_{smin} to T_{smax}) (t_s) | 60-120 seconds | 60-120 seconds |
| Average ramp-up rate (T_{smax} to T_p) | 3 °C/second max. | 3°C/second max. |
| Liquidous temperature (T_L) | 183 °C | 217 °C |
| Time at liquidous (t_L) | 60-150 seconds | 60-150 seconds |
| Peak package body Temperature (T_p)* | See Classification Temp in table 1 | See Classification Temp in table 2 |
| Time (t_p)** within 5°C of the specified classification temperature (T_c) | 20** seconds | 30** seconds |
| Average ramp-down rate (T_p to T_{smax}) | 6 °C/second max. | 6 °C/second max. |
| Time 25°C to peak temperature | 6 minutes max. | 8 minutes max. |
| *Tolerance for peak profile Temperature (T_p) is defined as a supplier minimum and a user maximum. | | |
| ** Tolerance for time at peak profile temperature (t_p) is defined as a supplier minimum and a user maximum. | | |



Table 1. SnPb Eutectic Process ±Classification Temperatures (Tc)

| Package Thickness | Volume mm ³ <350 | Volume mm ³ ≥350 |
|-------------------|--------------------------------|--------------------------------|
| <2.5 mm | 235 ℃ | 220 ℃ |
| • P P | 220 ℃ | 220 ℃ |

Table 2. Pb-free Process ±Classification Temperatures (Tc)

| Package Thickness | Volume mm ³ <350 | Volume mm ³ 350-2000 | Volume mm ³ ≥2000 |
|-------------------|--------------------------------|------------------------------------|---------------------------------|
| <1.6 mm | 260 ℃ | 260 ℃ | 260 ℃ |
| 1.6 mm ±2.5 mm | 260 ℃ | 250 ℃ | 245 ℃ |
| ≥2.5 mm | 250 ℃ | 245 ℃ | 245 ℃ |