

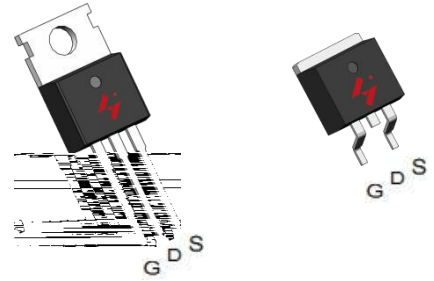

--

-
-
-
-

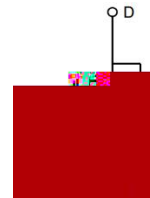

-
-
-



		
---	---	--

(

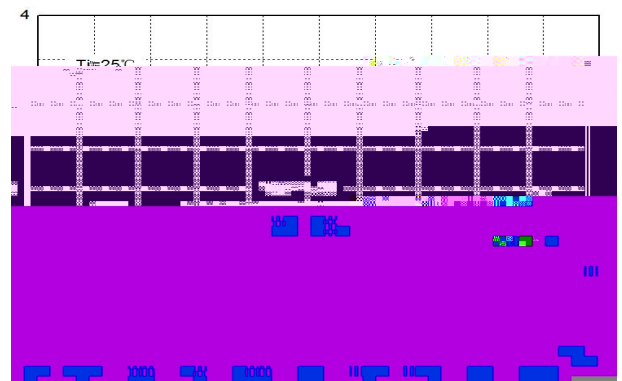
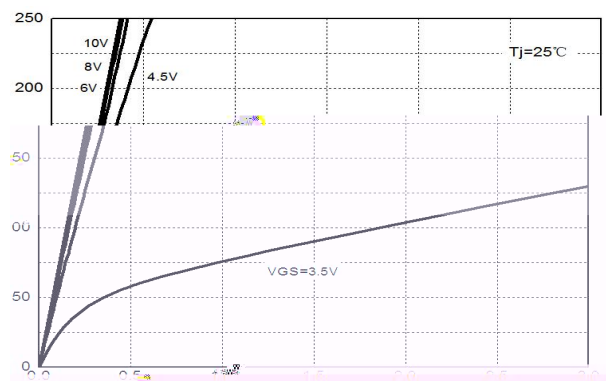
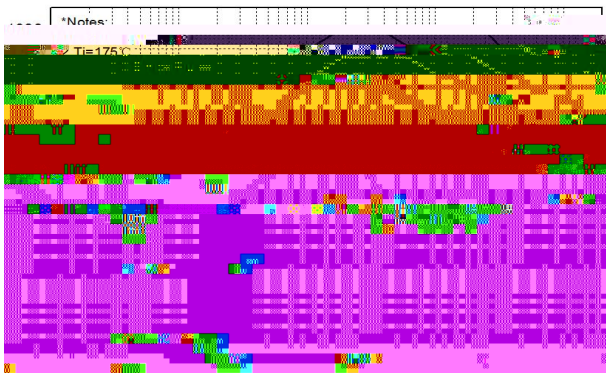
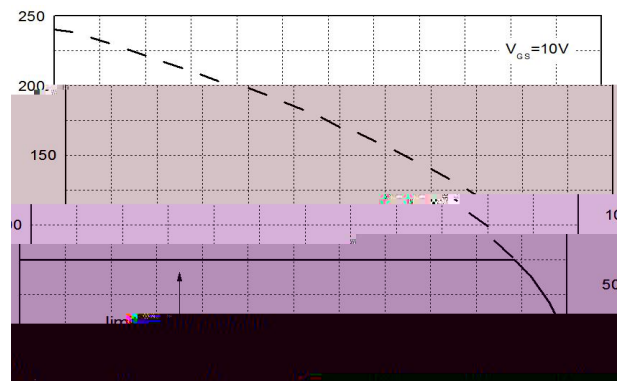
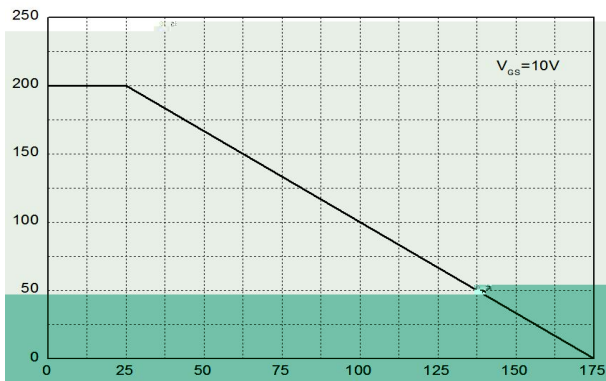

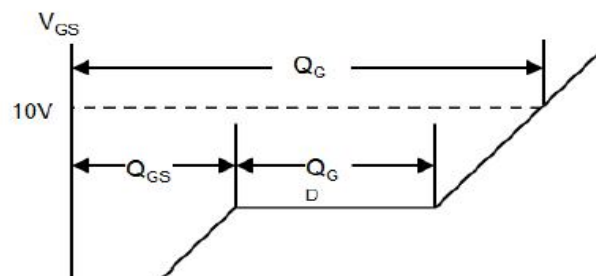
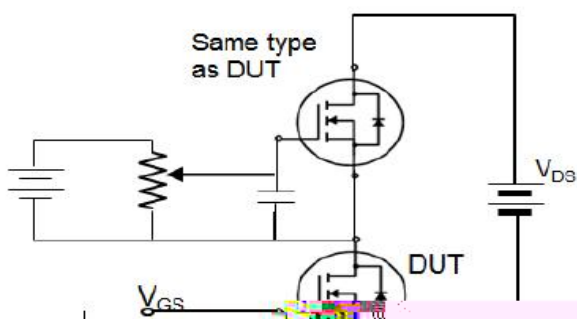
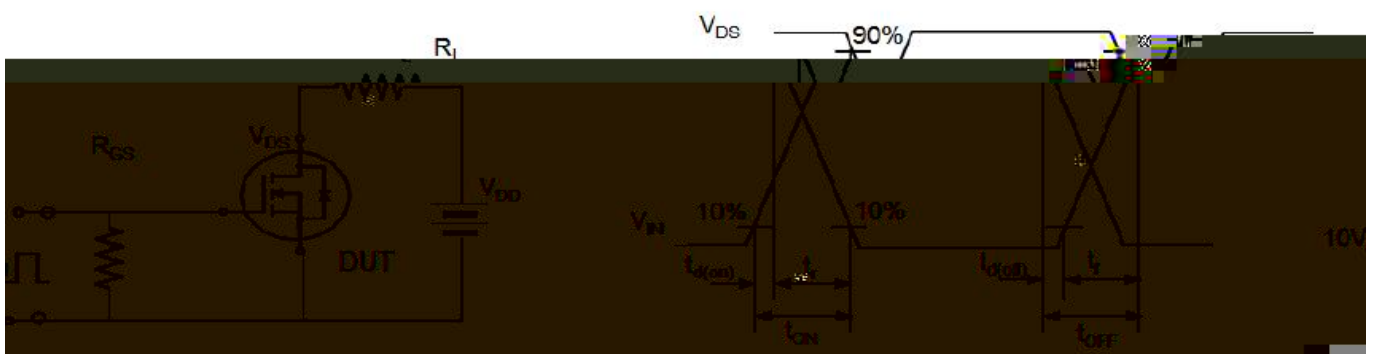
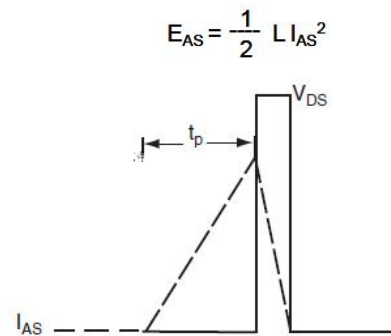
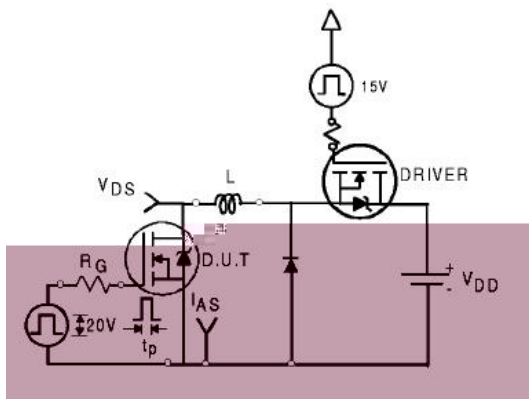

10V

10V

10V

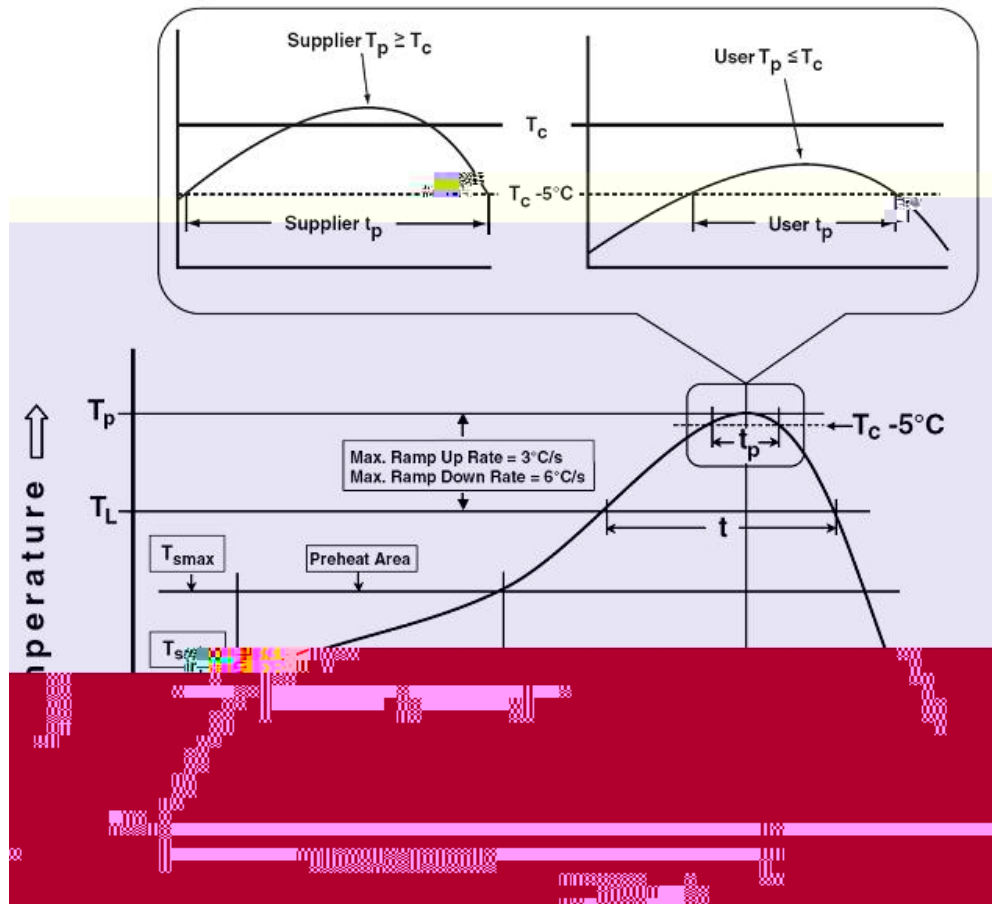

&
