

HYG045P03LQ2S

Absolute Maximum Ratings

Symbol	Parameter	Rating	Unit	
Common Ratings (T _c =25°C Unless Otherwise Noted)				
V _{DSS}	Drain-Source Voltage	-30	V	
V _{GSS}	Gate-Source Voltage	±20	V	
T _J	Junction Temperature Range	-55 to 175	°C	
T _{STG}	Storage Temperature Range		°C	
I _S	Source Current-Continuous(Body Diode)	T _c =25°C	-16	A
Mounted on Large Heat Sink				
I _{DM}	Pulsed Drain Current *	T _c =25°C	-58	A
I _D	Continuous Drain Current	T _c =25°C	-16	A
		T _c =100°C	-11	A
P _D	Maximum Power Dissipation	T _c =25°C	3	W
		T _c =100°C	1.5	W
R _{JA}	Thermal Resistance, Junction-to-Ambient **		50	°C/W
E _{AS}	Single Pulsed-Avalanche Energy ***	L=0.1mH	200	mJ

Note: * Repetitive rating; pulse width limited by max.junction temperature.

** Surface mounted on 1in2 FR-4 board.

*** Limited by T_{Jmax} , starting T_J=25°C, L = 0.1mH, R_G= 25Ω, V_{GS}=10V.

Electrical Characteristics

 (T_c =25°C Unless Otherwise Noted)

Symbol	Parameter	Test Conditions	HYG045P03LQ2			Unit
			Min	Typ.	Max	
Static Characteristics						
BV _{DSS}	Drain-Source Breakdown Voltage	V _{GS} =0V, I _{DS} =-250μA	-30	-	-	V
I _{DSS}	Drain-to-Source Leakage Current	V _{DS} =-30V, V _{GS} =0V	-	-	-1	μA
		T _J =125°C	-	-	-50	μA
V _{GS(th)}	Gate Threshold Voltage	V _{DS} =V _{GS} , I _{DS} =-250μA	-1.0	-1.7	-3.0	V
I _{GSS}	Gate-Source Leakage Current	V _{GS} =±20V, V _{DS} =0V	-	-	±100	nA
R _{DS(ON)}	Drain-Source On-State Resistance	V _{GS} =-10V, I _{DS} =-10A	-	5.6	6.7	mΩ
R _{DS(ON)}	Drain-Source On-State Resistance	V _{GS} =-4.5V, I _{DS} =-10A	-	8.0	10.4	mΩ
Diode Characteristics						
V _{SD}	Diode Forward Voltage	I _{SD} =-10A, V _{GS} =0V	-	-0.80	-1.20	V
t _{rr}	Reverse Recovery Time	I _{SD} =-10A, dI _{SD} /dt=100A/μs	-	21	-	ns
Q _{rr}	Reverse Recovery Charge		-	11	-	nC

Electrical Characteristics (Cont.) (Tc =25°C Unless Otherwise Noted)

Symbol	Parameter	Test Conditions	HYG045P03LQ2			Unit
			Min	Typ.	Max	
Dynamic Characteristics						
R _G	Gate Resistance	V _{GS} =0V, V _{DS} =0V, F=100KHz	-	4.4	-	Ω
C _{iss}	Input Capacitance	V _{GS} =0V, V _{DS} =-25V, Frequency=100KHz	-	4712	-	pF
C _{oss}	Output Capacitance					
C _{rss}	Reverse Transfer Capacitance					
t _{d(ON)}	Turn-on Delay Time	V _{DD} =-20V, R _G =4 Ω, I _{DS} =-10A, V _{GS} =-10V	-	12	-	ns
T _r	Turn-on Rise Time					
t _{d(OFF)}	Turn-off Delay Time					
T _f	Turn-off Fall Time					
Gate Charge Characteristics						
Q _g	Total Gate Charge(V _{GS} =-10V)	V _{DS} =-24V, I _{DS} =-10A	-	109	-	nC
Q _g	Total Gate Charge(V _{GS} =-4.5V)		-	57	-	
Q _{gs}	Gate-Source Charge		-	17	-	
Q _{gd}	Gate-Drain Charge		-	29	-	
V _{plateau}	Gate plateau voltage		-	-3.3	-	V

Note: *Pulse test, pulse width 300us, duty cycle 2%

Typical Operating Characteristics

Figure 1: Power Dissipation

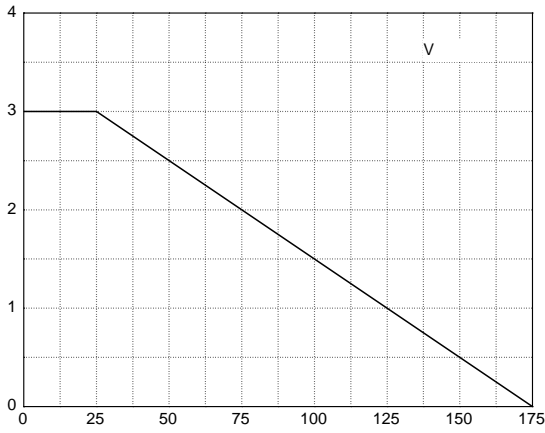

Figure 2: Drain Current

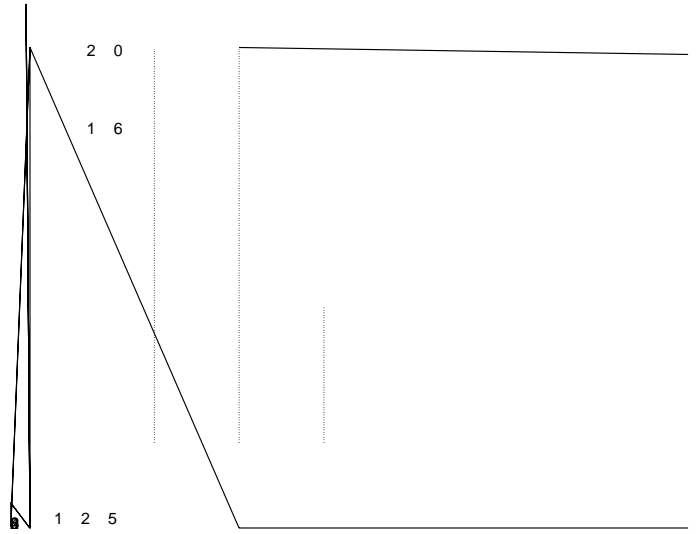

Figure 3: Safe Operation Area

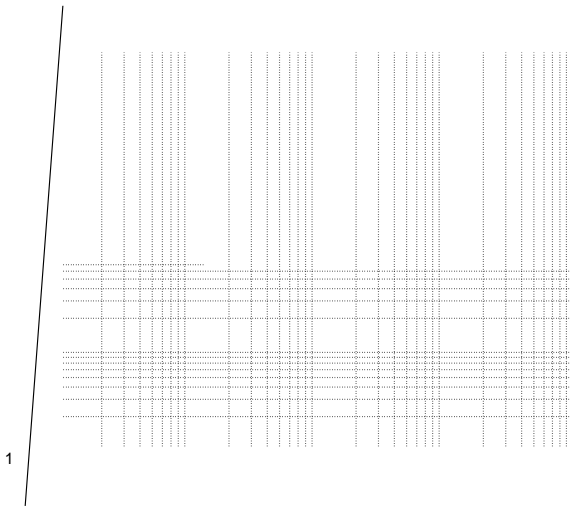

Figure 4: Thermal Transient Impedance



Figure 5: Output Characteristics

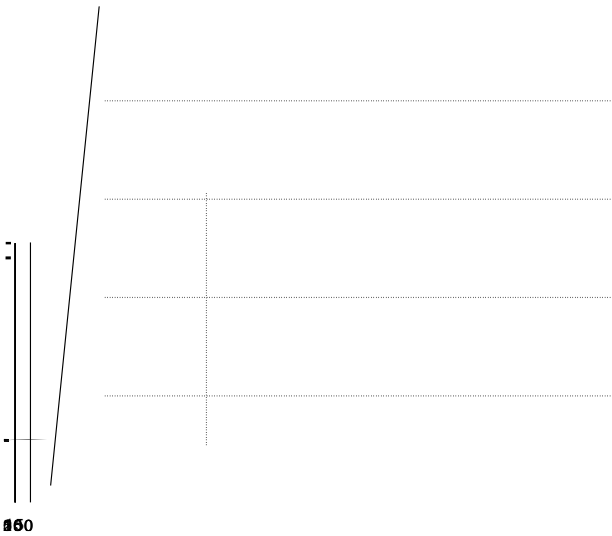
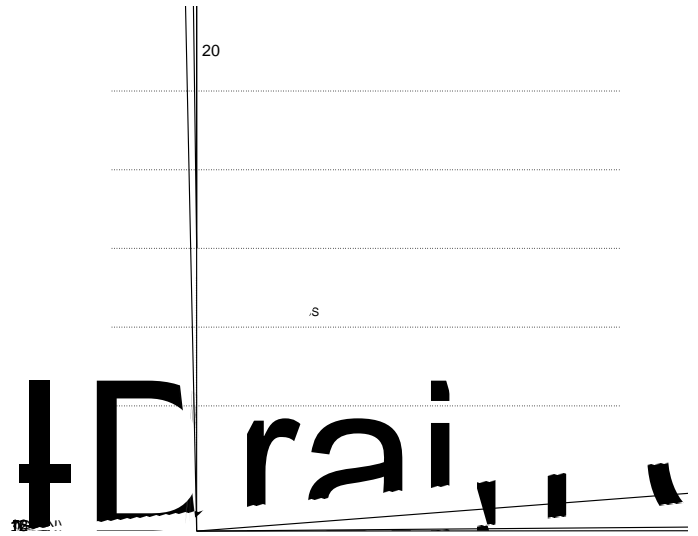

Figure 6: Drain-Source On Resistance



Typical Operating Characteristics(Cont.)

Figure 7: On-Resistance vs. Temperature

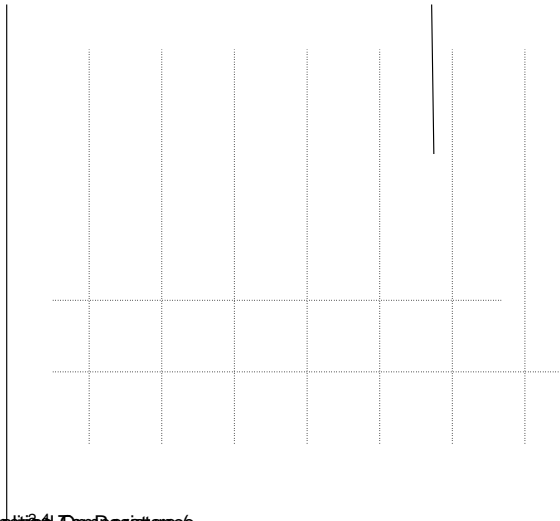

Figure 8: Source-Drain Diode Forward



Figure 9: Capacitance Characteristics

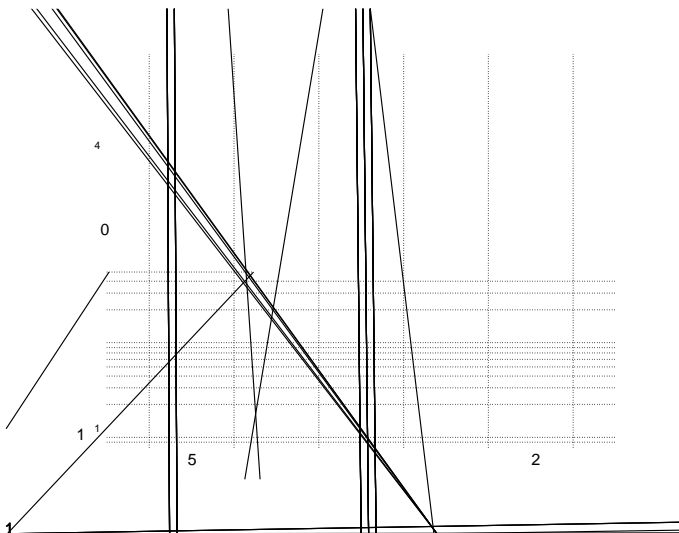
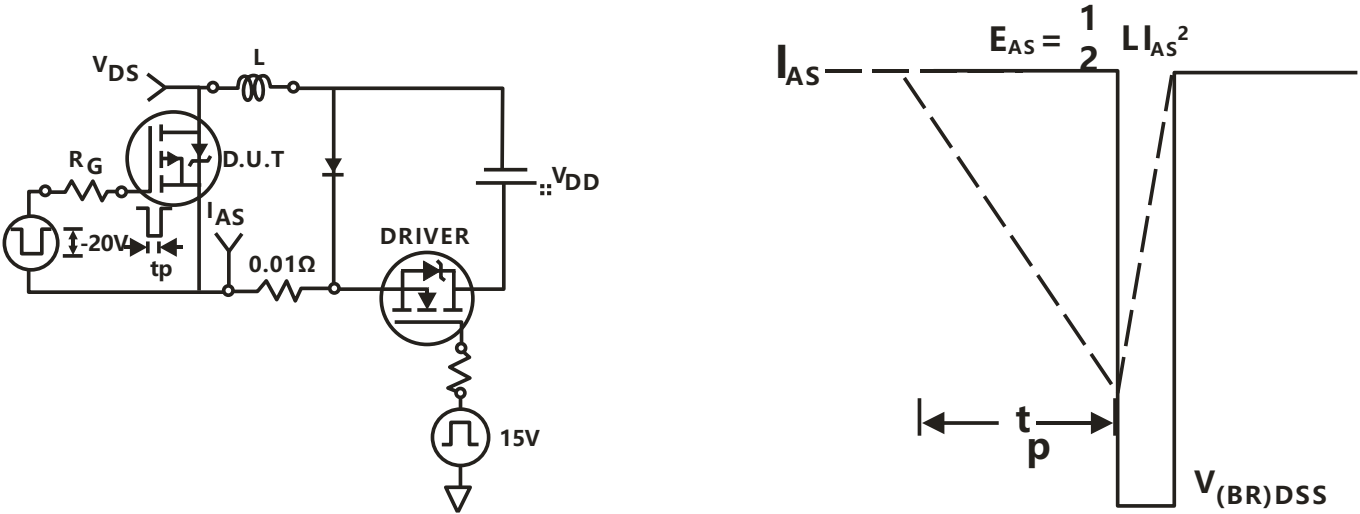

Figure 10: Gate Charge Characteristics

HYG045P03LQ2S

Avalanche Test Circuit



Switching Time Test Circuit

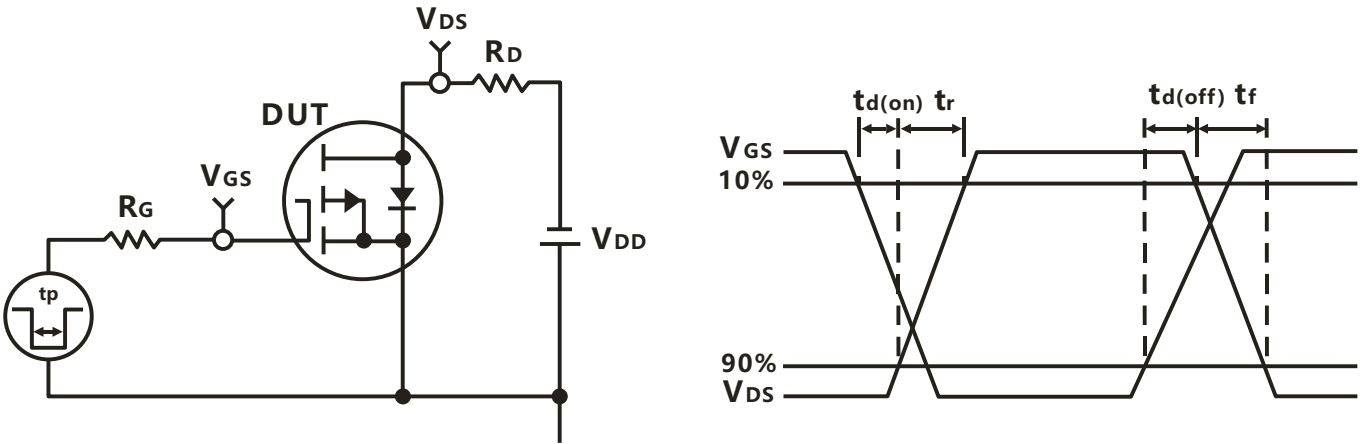

Gate Charge Test Circuit

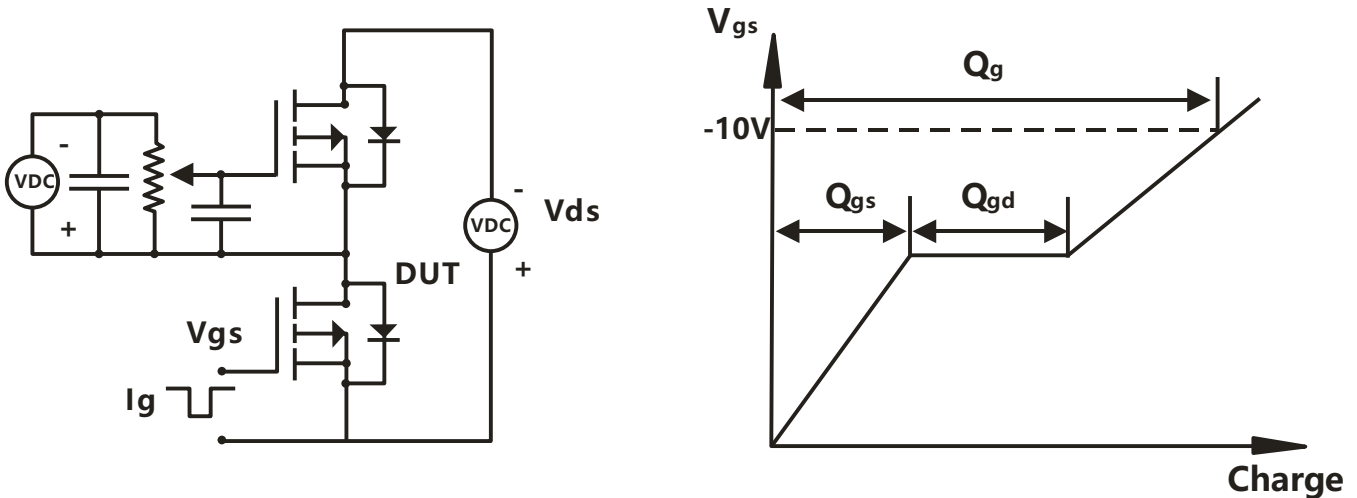

Device Per Unit

Package Type	Unit	Quantity
SOP8L	Reel	2500

Package Information

COMMON DIMENSIONS			
SYMBOL	mm		
	MIN	NOM	MAX
A	-	-	1.75
A1	0.10	-	0.225
A2	1.30	1.40	1.50
A3	0.60	0.65	0.70
b	0.39	-	0.

Note:

1. Follow JEDEC MS-012AA.
2. Dimension D" does not include mold flash, protrusions or gate burrs. Mold flash, protrusion or gate burrs shall not exceed 6 mil per side.
3. Dimension E" does not include inter-lead flash or protrusions. Inter-lead flash and protrusions shall not exceed 10 mil per side.

Carrier Tape & Reel Dimensions

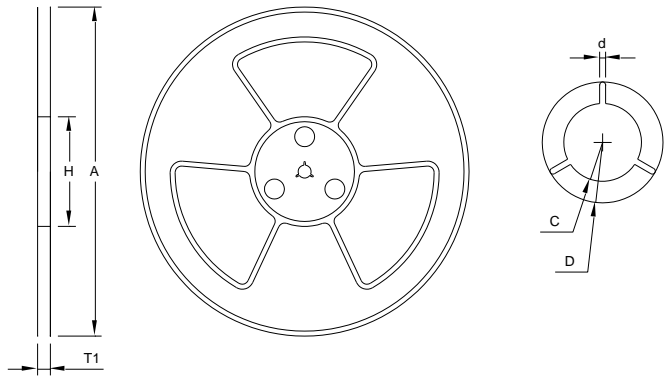
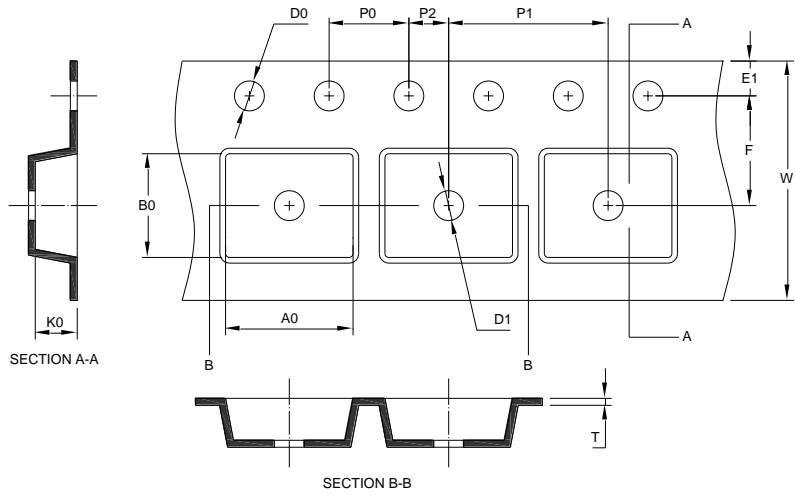

Application	A	H	T1	C	d	D	W	E1	F
SOP8L	330 2.00	50 MIN	12.4+2.00 -0.20	13.0+0.50 -0.20	1.5 MIN	20.2 MIN	12.0 0.30	1.75 0.10	5.5 0.05
	P0	P1	P2	D0	D1	T	A0	B0	K0
	4.0 0.10	8.0 0.10	2.0 0.05	1.5+0.10 -0.00	1.5 MIN	0.6+0.00 -0.40	6.40 0.20	5.20 0.20	2.10 0.20

Taping Direction Information

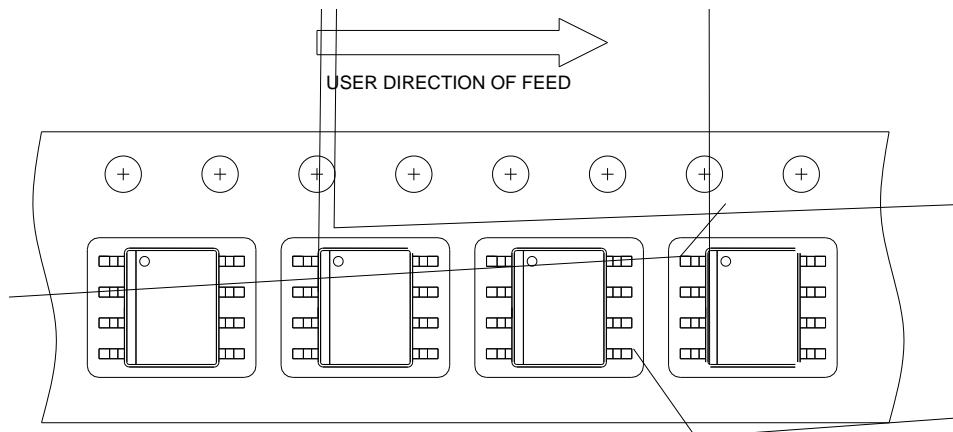

Classification Profile



Classification Reflow Profiles

Profile Feature	Sn-Pb Eutectic Assembly	Pb-Free Assembly
Preheat & Soak		
Temperature min (T_{smin})	100 °C	150 °C
Temperature max (T_{smax})	150 °C	200 °C
Time (T_{smin} to T_{smax}) (t_s)	60-120 seconds	60-120 seconds
Average ramp-up rate (T_{smax} to T_P)	3 °C/second max.	3°C/second max.
Liquidous temperature (T_L)	183 °C	217 °C
Time at liquidous (t_L)	60-150 seconds	60-150 seconds
Peak package body Temperature (T_P)*	See Classification Temp in table 1	See Classification Temp in table 2
Time (t_P)** within 5°C of the specified classification temperature (T_c)	20** seconds	30** seconds
Average ramp-down rate (T_P to T_{smax})	6 °C/second max.	6 °C/second max.
Time 25°C to peak temperature	6 minutes max.	8 minutes max.
*Tolerance for peak profile Temperature (T_P) is defined as a supplier minimum and a user maximum.		
** Tolerance for time at peak profile temperature (t_P) is defined as a supplier minimum and a user maximum.		

Table 1. SnPb Eutectic Process – Classification Temperatures (Tc)

Package Thickness	Volume mm³	Volume mm³
<2.5 mm	<350	≥350
	235 °C	220 °C