

Ω

Ω

-
-
-

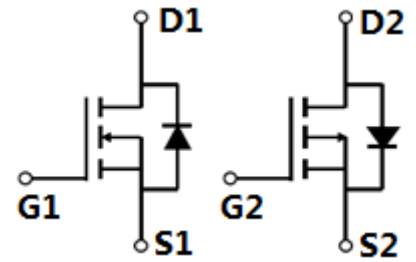

-
-
-

--	--



--	--	--	--	--

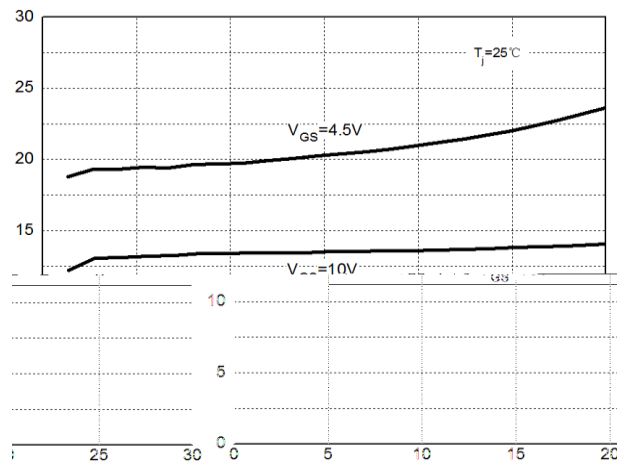
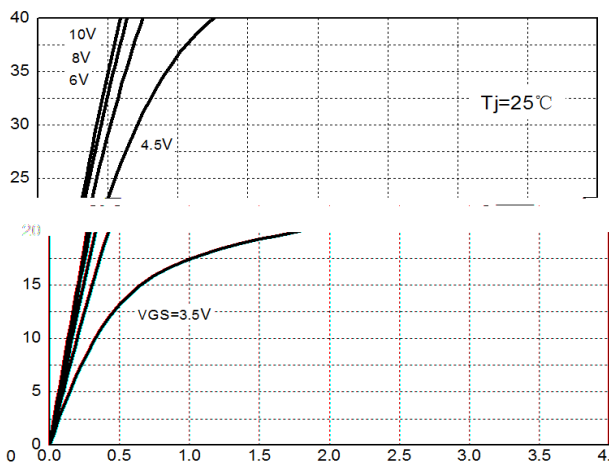
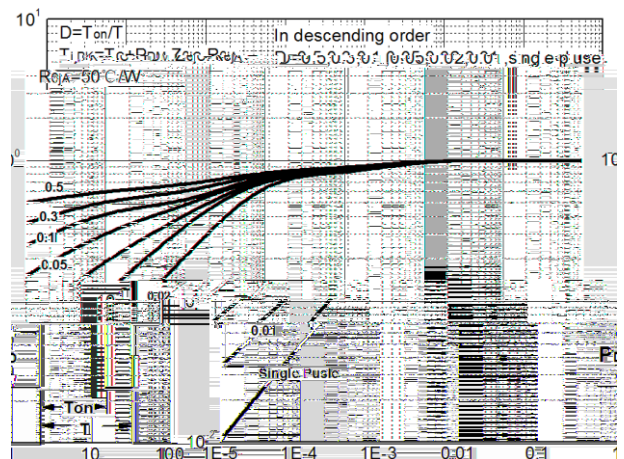
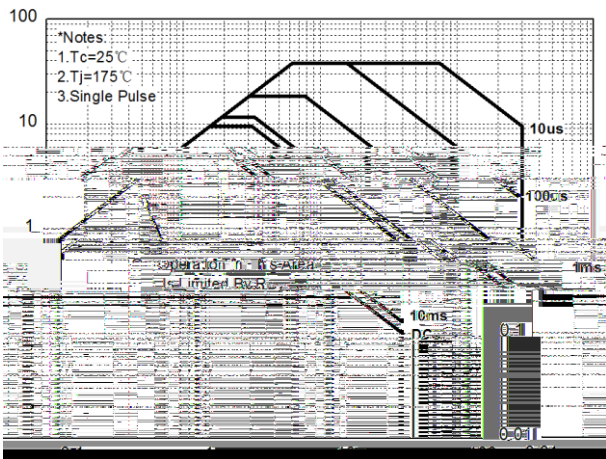
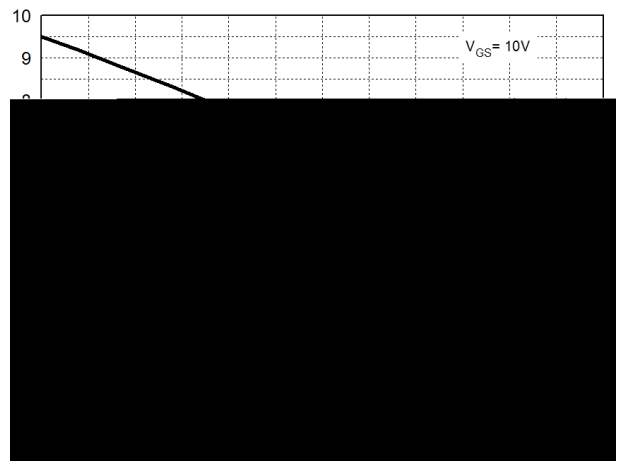
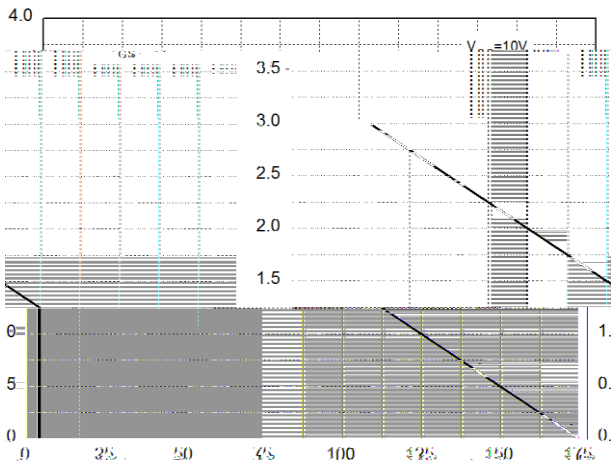

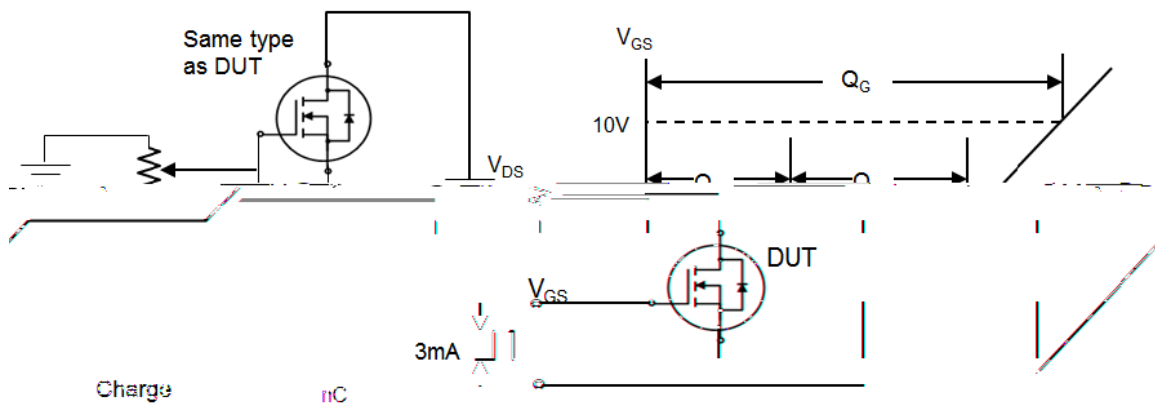
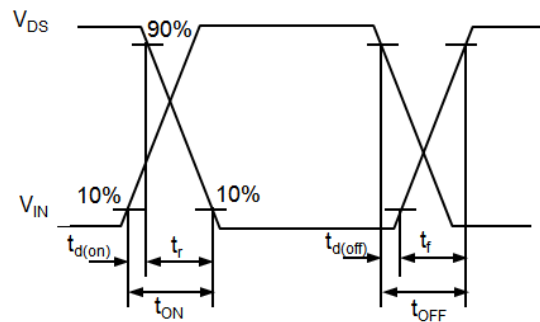
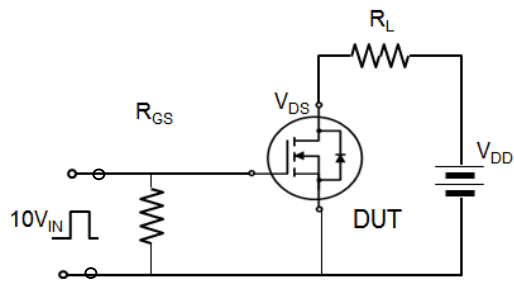
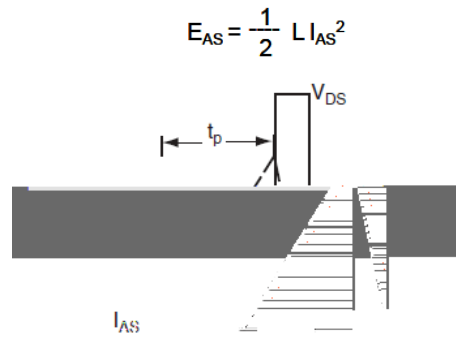
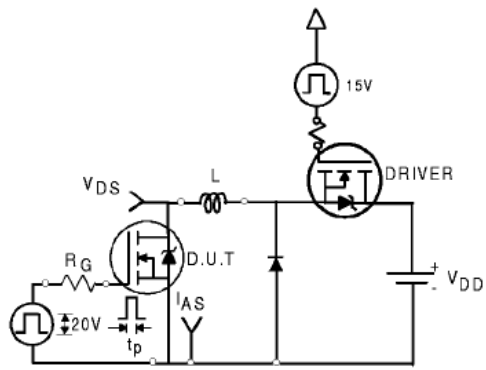

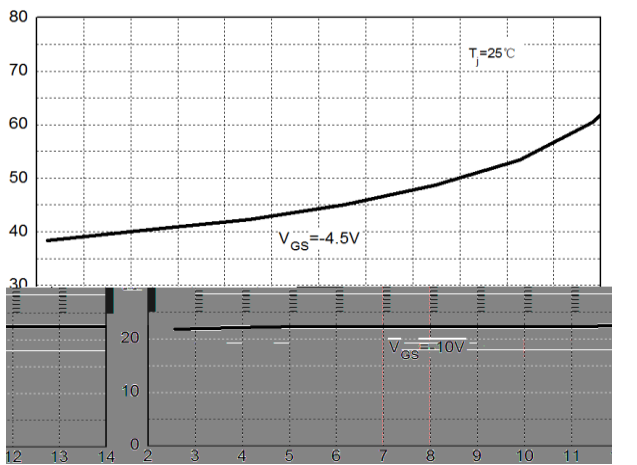
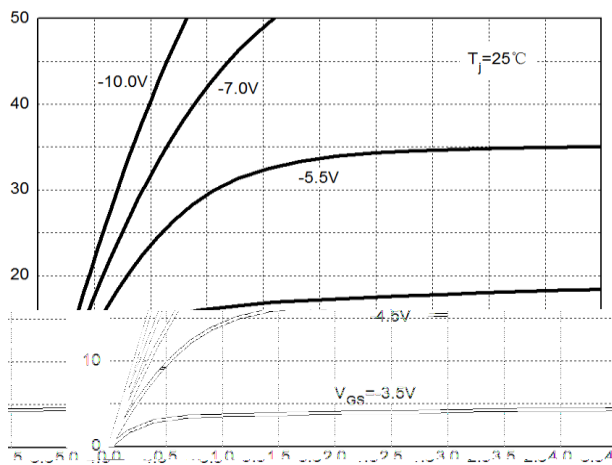
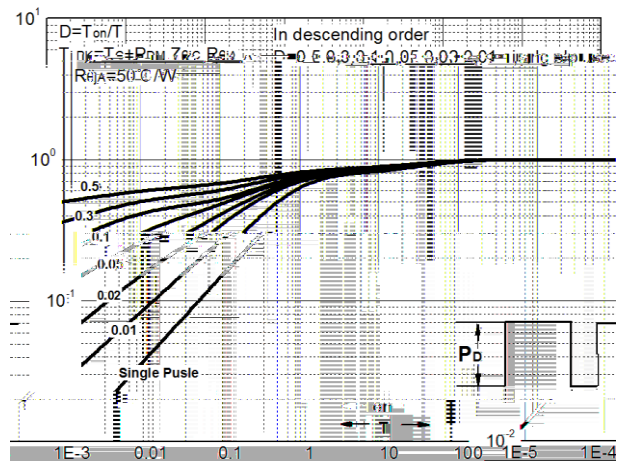
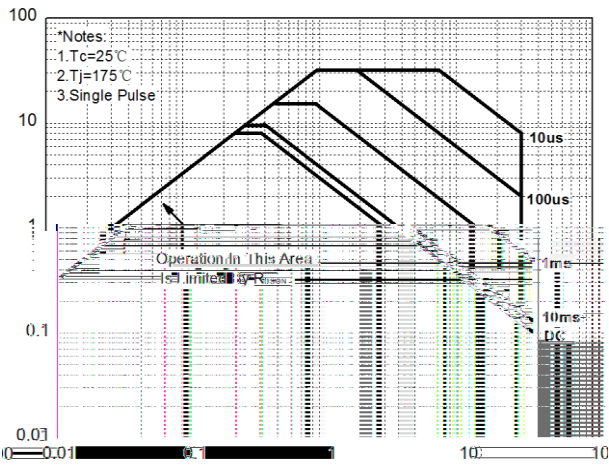
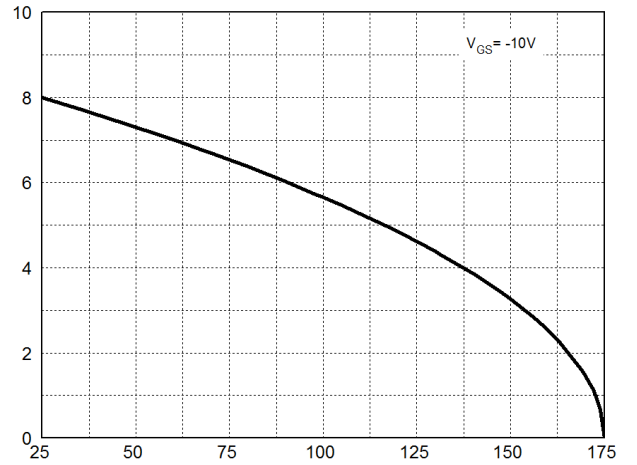
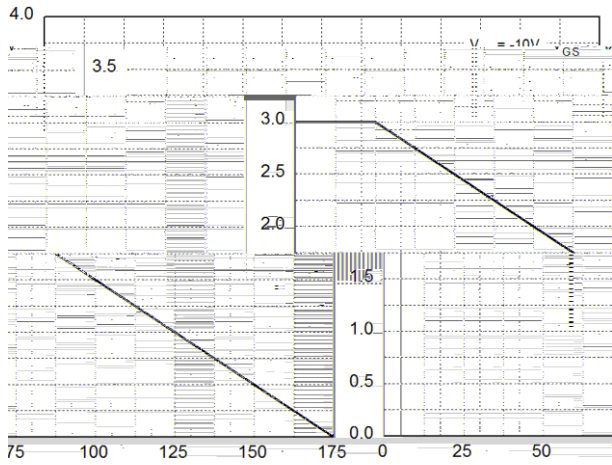

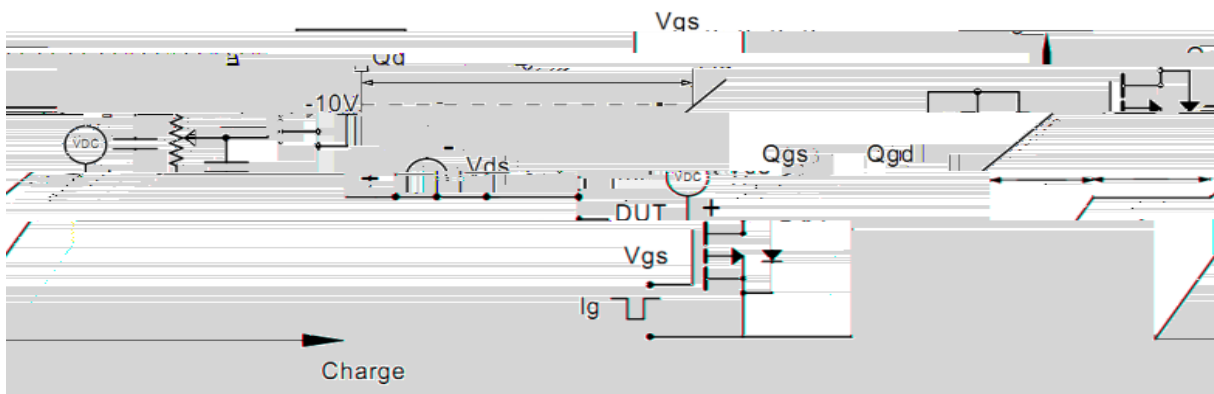
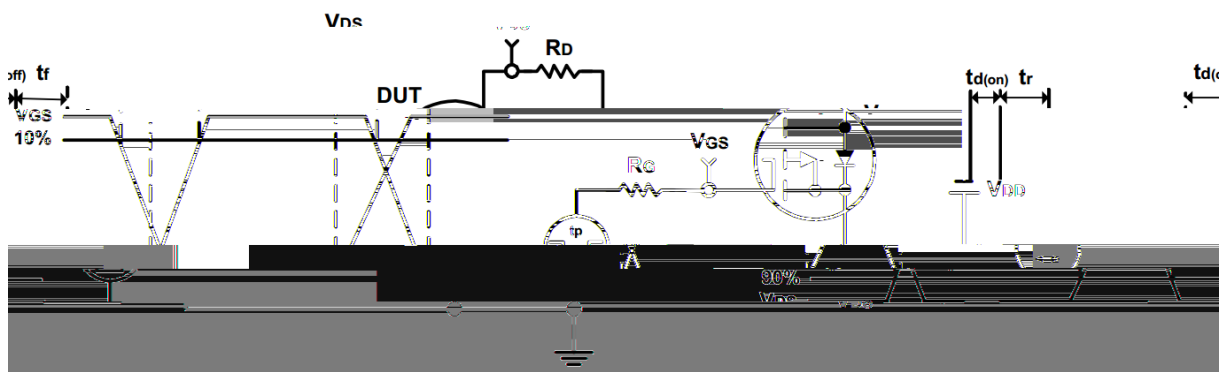
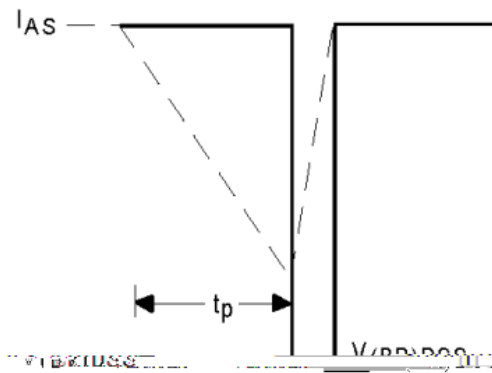
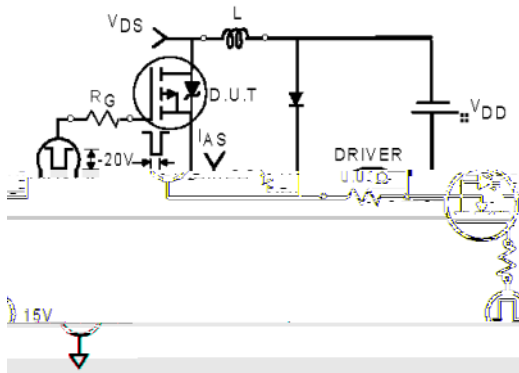

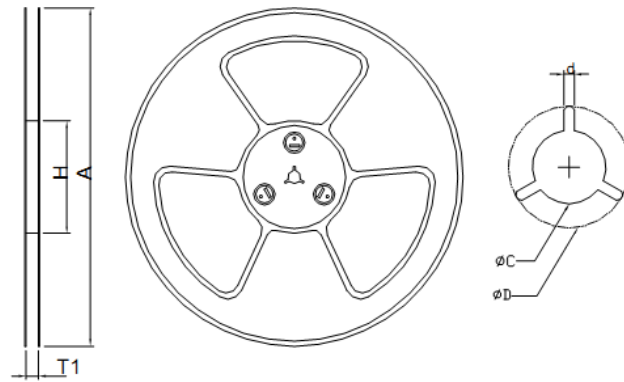
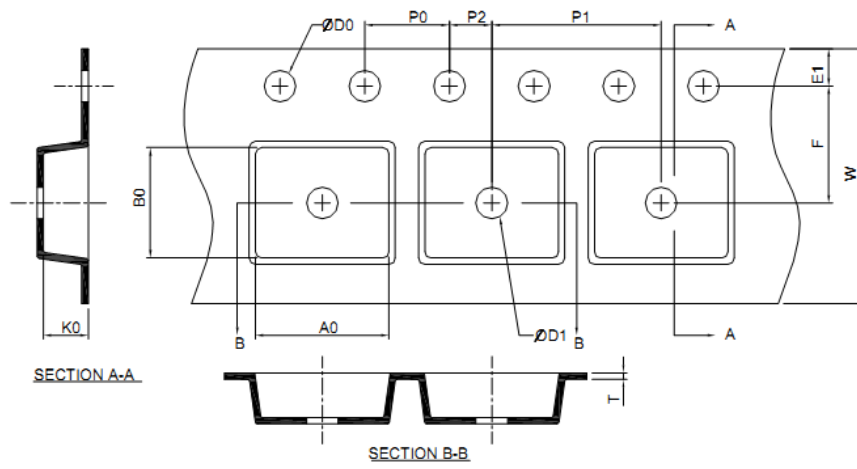

Application	A	H	T1	C	d	D	W	E1	E
SOP8L	2.0 0.05	1.5+0.10 -0.00	1.5 MIN.	0.6+0.00 -0.40	6.40 0.20	5.20 0.20	2.10 0.20	4.0 0.10	8.0 0.10

(mm)

USER DIRECTION OF FEED

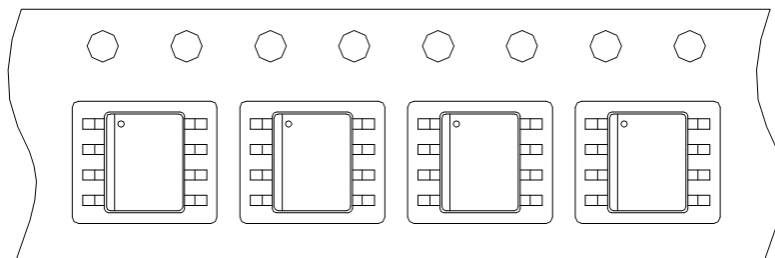

	3	3

	3	3	3
